

SECTION A-A

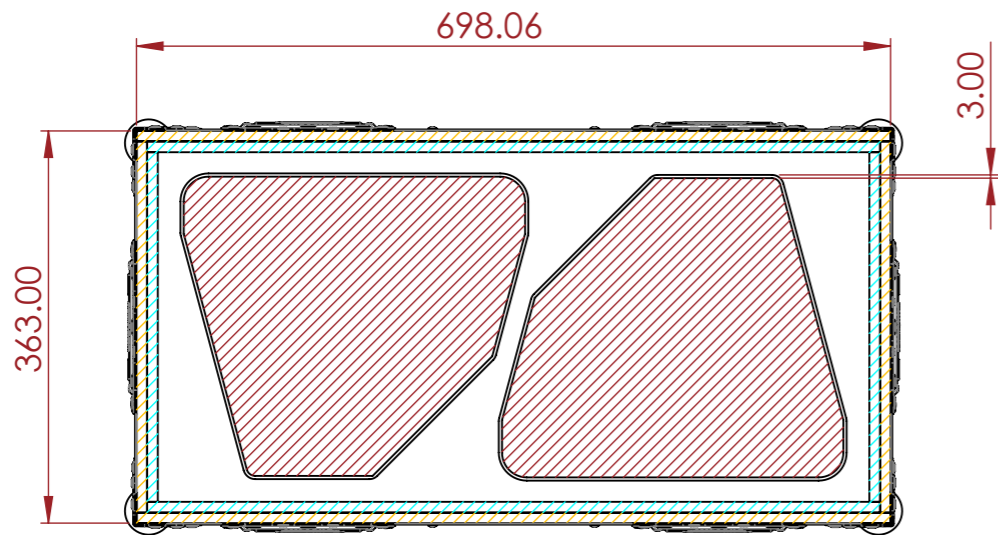

SECTION B-B

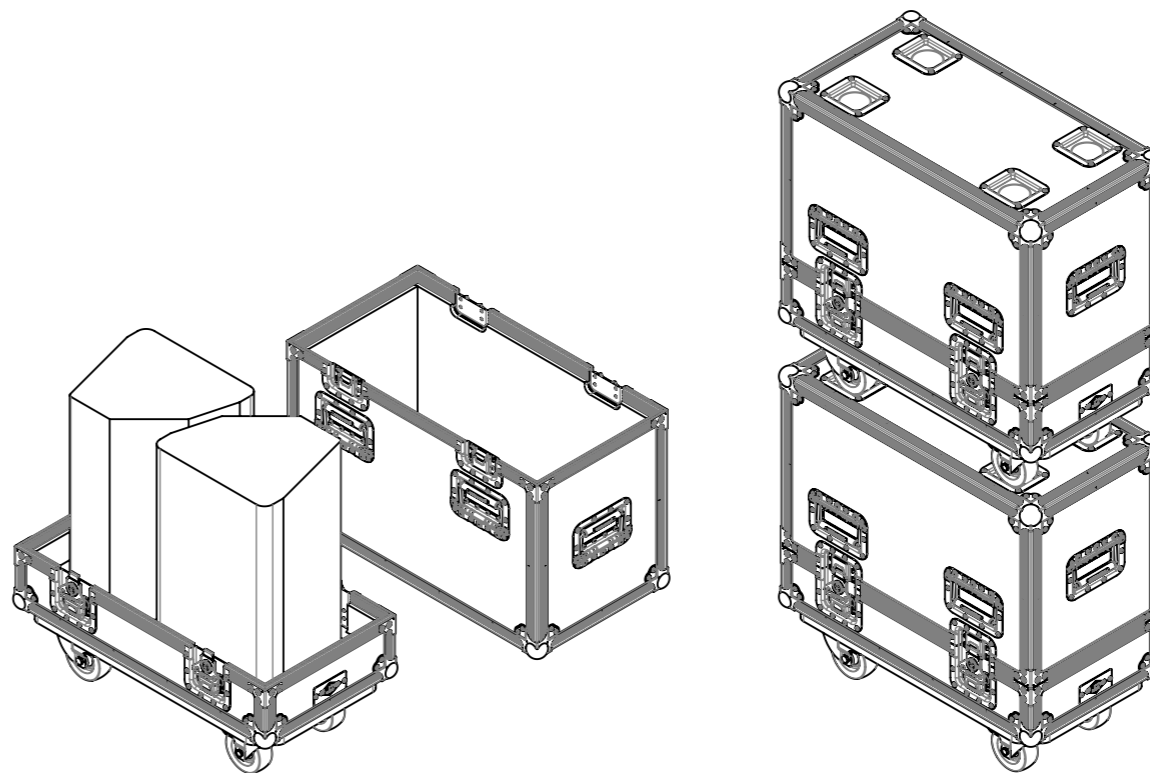

NOTES:

REV	DESCRIPTION	DATE
0	ORIGINAL ISSUE	10/31/2022

ESTIMATED WEIGHT:

26.76

QUANTITY:

1

ITEM CODE:

SPK-NEXO-PS10-R2-ST

DRAWN BY:

KI

CHECKED BY:

AS

SCALE:

NTS



ADD : 2/42 Dunn Road
 Smeaton Grange, NSW 2567
 PH : (02) 4646 1199
 MAIL : sales@showtools.com.au
 WEB : www.showtools.com.au