

PRODUCT FEATURES

CONSTRUCTION

- 12MM BIRCH VENEER PLYWOOD WITH HPL EXTERIOR FACE AND PVC INTERIOR FACE
- PENN ELCOM HARDWARE

FEATURES

- HINGED LID DESIGN
- LOGO ENGRAVED ON FRONT AND BACK OF THE CASE
- PLYWOOD STRUCTURE TO HOLD THE EQUIPMENT
- 2X LARGE LATCHES
- 4X RECESSED HANDLES
- 1X CORNER HANDLE ON LID FOR EASE OF ACCESSIBILITY

KEY MEASUREMENTS

- TRUCK FRIENDLY DIMENSIONS

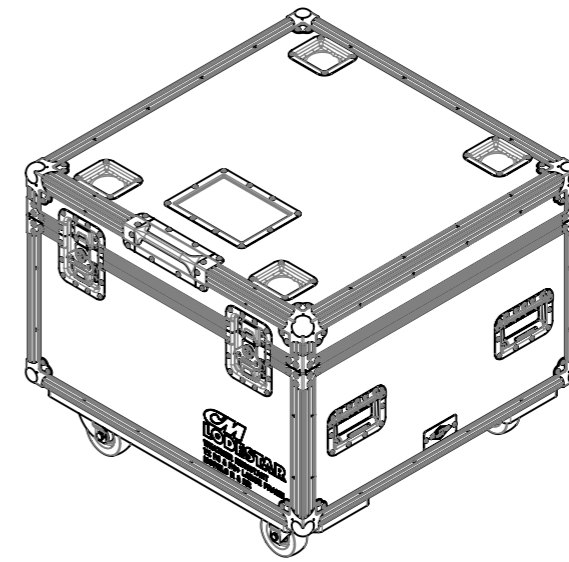
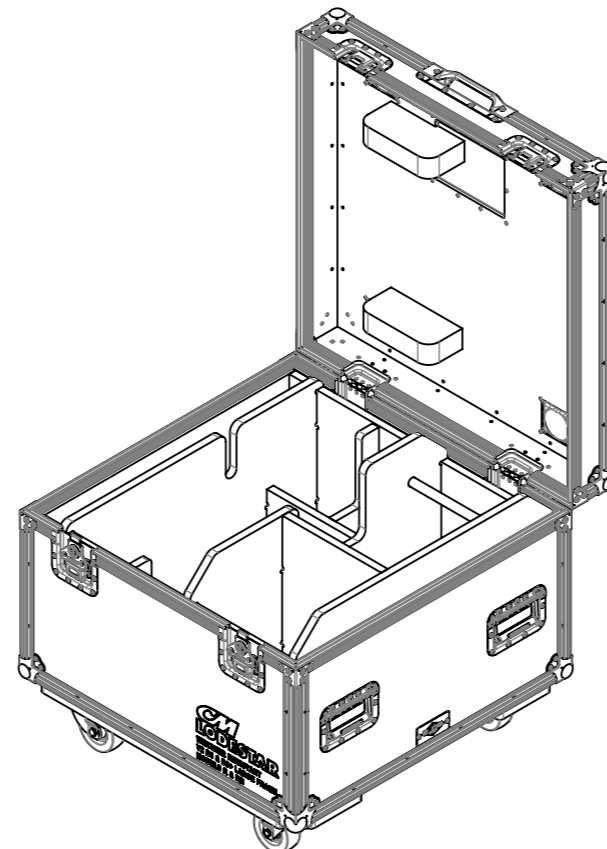
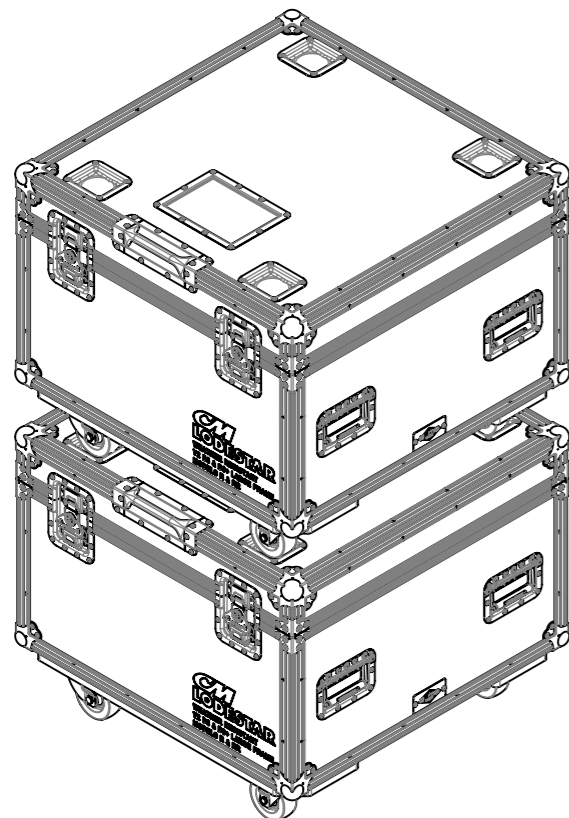
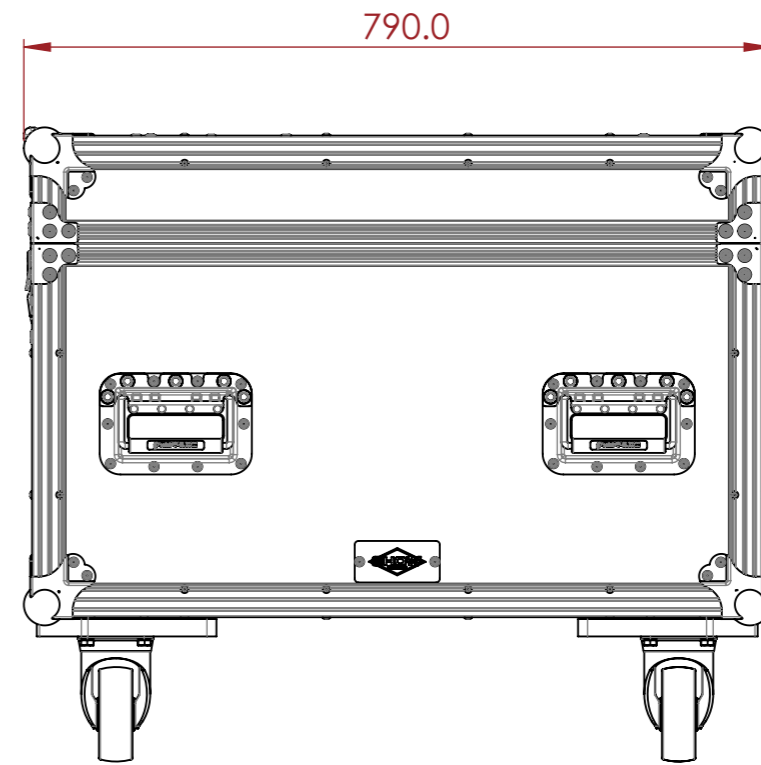
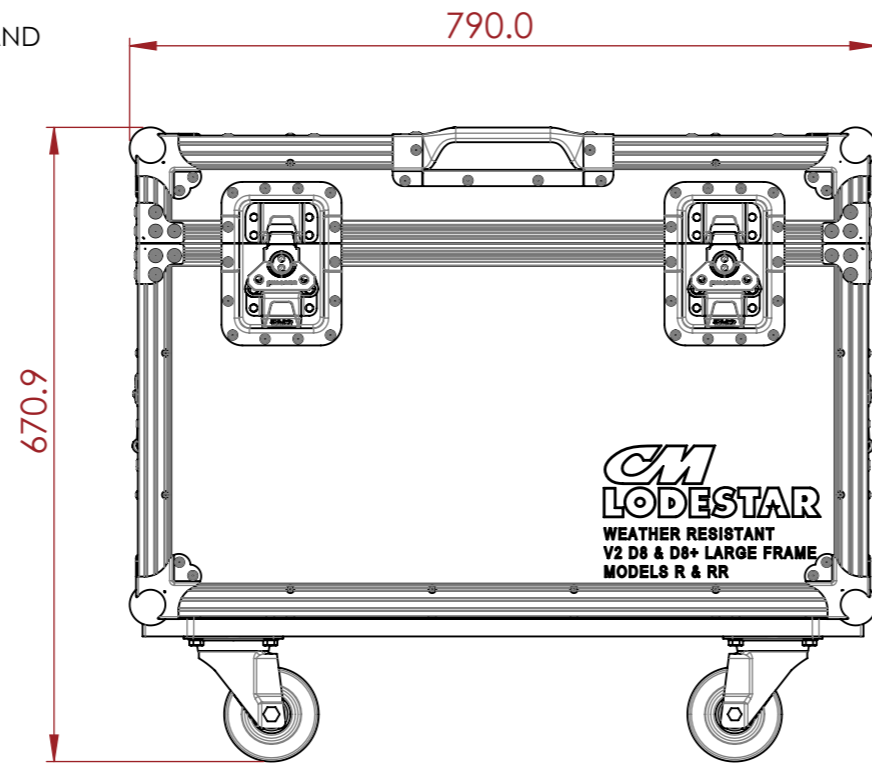

NOTES:

ESTIMATED WEIGHT:

61.53 KG

QUANTITY:

1

ITEM CODE:

RIG-CM-2TNHRR-88

DRAWN BY:

K.I

CHECKED BY:

AS

SCALE:

NTS



ADD : 2/42 Dunn Road
 Smeaton Grange, NSW 2567
 PH : (02) 4646 1199
 MAIL : sales@showtools.com.au
 WEB : www.showtools.com.au